

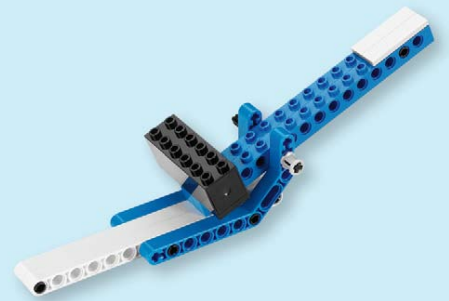

education

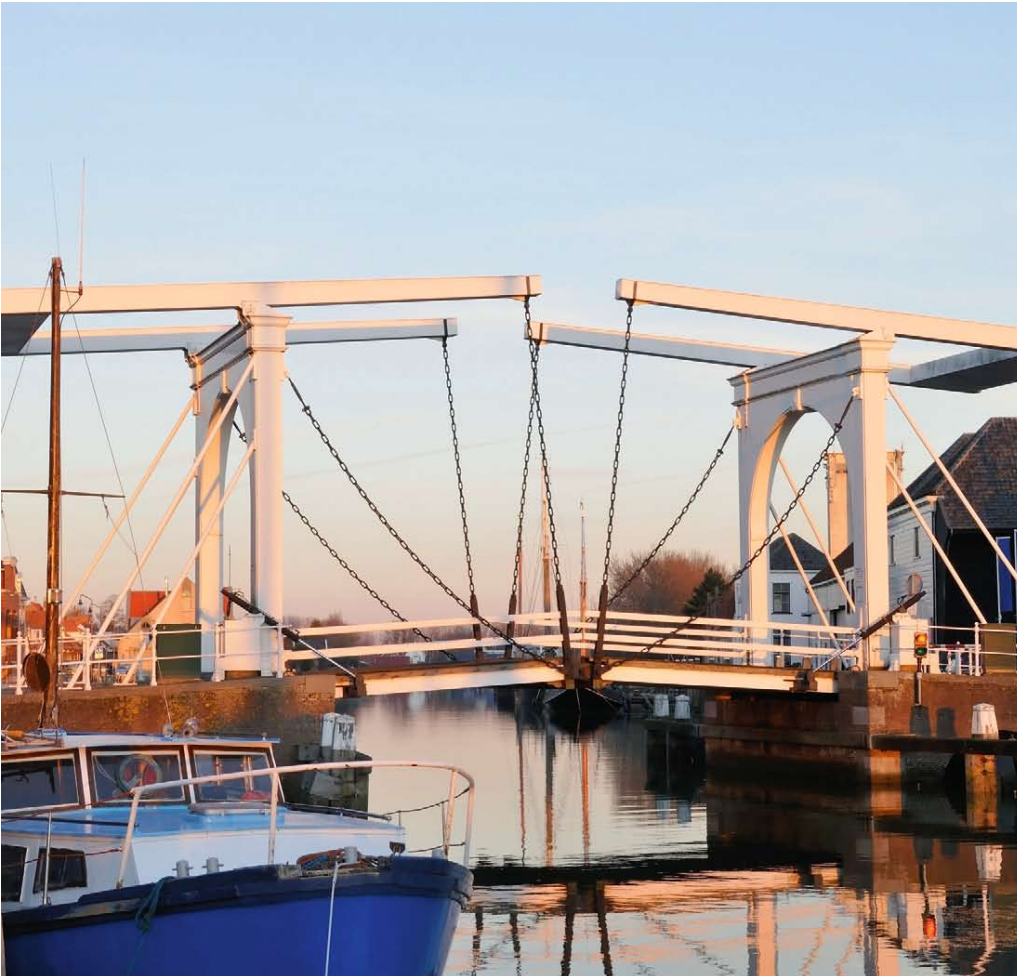

Lever

Student Worksheet

Simple Machines: Lever

The lever is probably the most commonly used simple machine. A lever is a rigid bar or solid object that is used to transfer force.

With a fulcrum, the lever can be used to change the force that is applied (effort), alter the direction, and change the distance of movement. Effort, a fulcrum and a load are three features that are common in every lever.

Depending on the positions of these shared features, you can distinguish between first, second or third class levers.

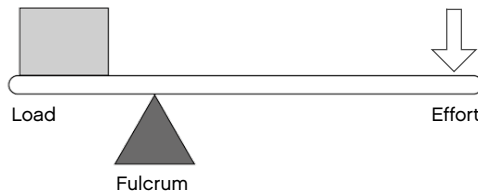

First class levers have the fulcrum positioned between the effort and the load. Common examples of first class levers include a seesaw, a crowbar, pliers, and scissors.

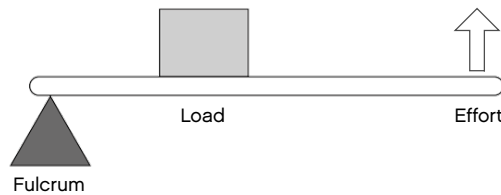

Second class levers have the fulcrum and the effort at opposite ends and the load positioned between the two. Common examples of second class levers include nut crackers, wheel barrows, and bottle openers.

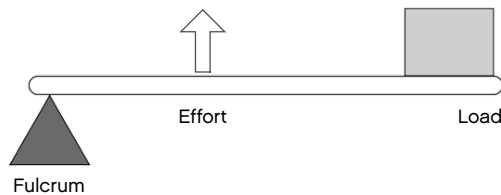

Third class levers have the fulcrum and the load at opposite ends and the effort positioned between the two. Common examples of third class levers include tweezers and ice tongs.

Did you know?

The term lever derives from the French word *levier* which means 'to raise'.

The mechanical advantage of a lever

The mechanical advantage of a lever is the ratio of the length of the effort arm to the length of the load arm.

It can be calculated using the following formula:

$$\text{Mechanical advantage} = \frac{\text{Length of effort arm}}{\text{Length of load arm}}$$

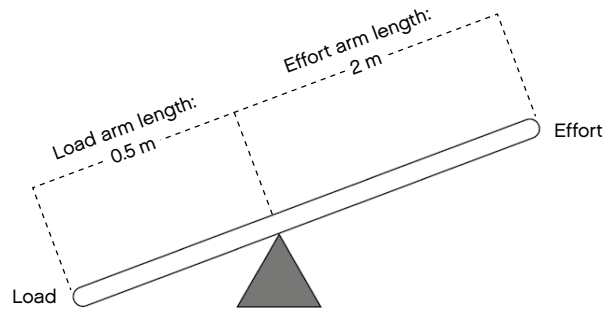

The mechanical advantage of this 1st class lever is:

$$\text{Mechanical advantage} = \frac{2 \text{ m}}{0.5 \text{ m}}$$

$$\text{Mechanical advantage} = 4$$

The amount of effort needed to lift a given load with any class of lever can be calculated using this formula:

$$\text{Effort force} \times \text{length of effort arm} = \text{Load force} \times \text{length of load arm}$$

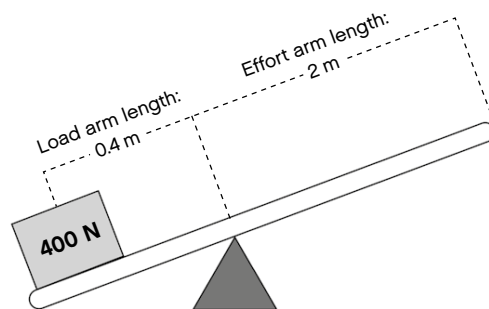

$$\text{Effort} \times 2 \text{ m} = 400 \text{ N} \times 0.4 \text{ m}$$

$$\text{Effort} = \frac{400 \text{ N} \times 0.4 \text{ m}}{2 \text{ m}}$$

$$\text{Effort} = 80 \text{ N}$$

Using this 1st class lever to lift a 400 N load would only need an effort of 80 N. However, the effort end of the lever must move five times the distance of the load.

A1**Build A1 book I, pages 2 to 3**

Calculate the mechanical advantage of this lever.
Then define the class of lever.

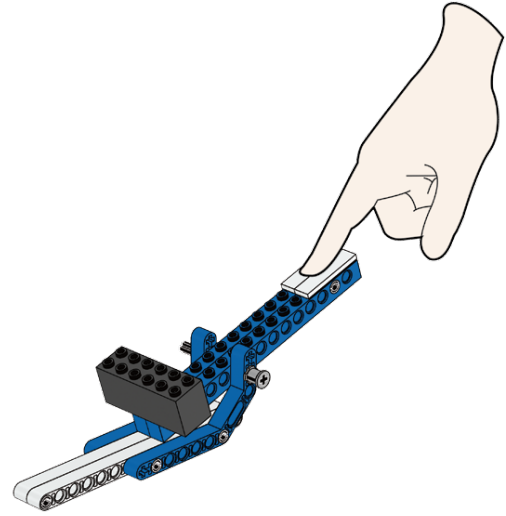
**A2****Build A2 book I, pages 4 to 5**

Calculate the mechanical advantage of this lever.
Then define the class of lever.

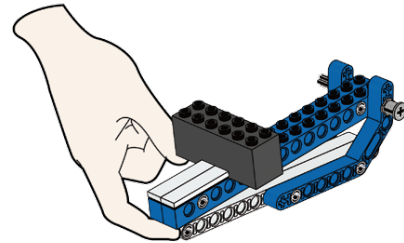
**A3****Build A3 book I, pages 6 to 7**

Calculate the mechanical advantage of this lever.
Then define the class of lever.

